

CONNECTING YOUR ANDROID TV SET-TOP BOX

Components included:



streaming media player
set-top box (STB)



power adapter

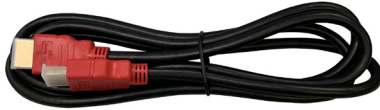

HDMI cable



AA batteries



remote control

Follow these steps:

1. Remove the STB and accessories from the box and plastic packaging—do not block vents or the remote control signal. Insert the included batteries into the remote control.
2. Connect the included HDMI cable to the HDMI 1 port on your TV, and the other end to the HDMI port on the back of the STB.
3. Connect the included power adapter to the 12V socket on the STB, then to an appropriate power source in your home.

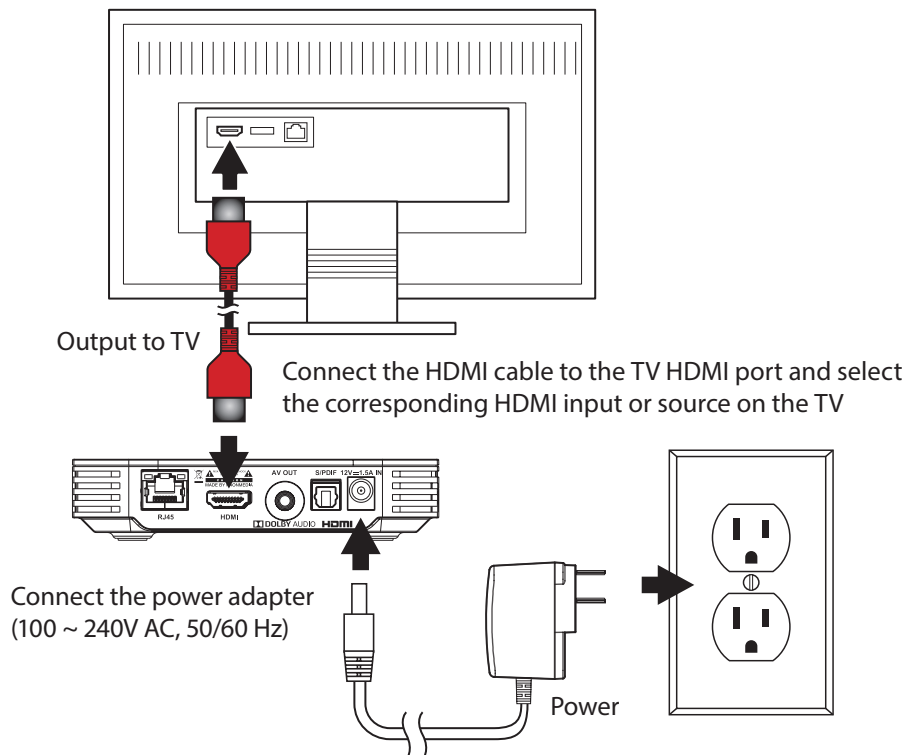

With your TV on, the STB will automatically begin the set-up process. During this process, you will need to connect to your home wireless network.

To connect to your network:

1. When you see the message “Connection is down,” press the **Select** button while the Cancel option is highlighted.
2. On the Android TV menu screen you will see a message “Ethernet is not connected.” Press up on the **Navigation** button twice to highlight the Settings menu icon (cog wheel) in the upper right corner of the screen and press **Select**.
3. A sidebar menu appears with Setting options. “Network” is already highlighted, press the **Select** button.
4. Press down on the **Navigation** button to highlight the correct network, then press **Select**.
5. Press left, right, up and down on the **Navigation** button to highlight letters, numbers and symbols on the on-screen keyboard and press the **Select** button to choose the character. Once complete, highlight the →| symbol and press **Select**.
6. Wait a few minutes while the STB connects to your network; the Network sidebar menu appears showing you confirmation you’re connected.
7. Press the **LIVE** button to launch the Arvig WiFi TV app.

If you need additional assistance, see the full instruction manual on arvig.com/WiFiTV for the Android TV STB.

